

ACDRA AIR-S

ACTUADOR NEUMÁTICO ROTATIVO TIPO SCOTCH-YOKE EN SIMPLE EFECTO

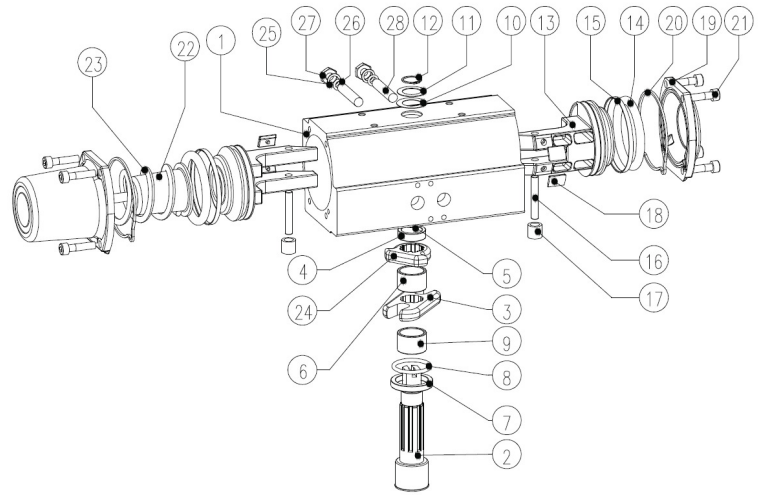

No.	PART NAME	MATERIALS	REMARKS
1	BODY	EXTRUDED ALUMINIUM ALLOY	HARD ANODIZED
2	SHAFT	STEEL ALLOY	NICKEL PLATED
3	CRANK	STEEL ALLOY	
4	BODY TOP BEARING	ENGINEERING PLASTIC	
5	BODY TOP O-RING	NBR / EPDM / FKM	STANDARD : NBR
6	TOP SHAFT ROLLER	ENGINEERING PLASTIC	
7	BODY BOTTOM BEARING	ENGINEERING PLASTIC	
8	BODY BOTTOM O-RING	NBR / EPDM / FKM	STANDARD : NBR
9	BOTTOM SHAFT ROLLER	ENGINEERING PLASTIC	APD100 ~ APD160 : AI DIECAST
10	BODY BOTTOM WASHER	STEEL ALLOY	SK5 (HRC53/Zn PLATED)
11	BODY TOP WASHER	STEEL ALLOY	SK5 (HRC53/Zn PLATED)
12	BODY SNAP RING	STEEL ALLOY	SK5 (HRC53/Zn PLATED)
13	PISTON	ALUMINIUM DIECASTING	
14	PISTON O-RING	NBR / EPDM / FKM	STANDARD : NBR
15	PISTON GUIDE RING	ENGINEERING PLASTIC	
16	PISTON PIN	STEEL ALLOY	
17	PISTON ROLLER	STEEL ALLOY	
18	PISTON PAD	ENGINEERING PLASTIC	
19	END COVER	ALUMINIUM DIECASTING	BLACK EPOXY COATED
20	COVER O-RING	NBR / EPDM / FKM	
21	COVER BOLT	STEEL ALLOY	
22	SPRING CAP	ENGINEERING PLASTIC	
23	SPRING	SPRING ALLOY	EPOXY COATED
24	STOPPER	STEEL ALLOY	
25	ADJUST WASHER	STAINLESS STEEL	
26	ADJUST NUT	STAINLESS STEEL	
27	ADJUST O-RING	NBR / EPDM / FKM	STANDARD : NBR
28	ADJUST BOLT	STEEL ALLOY	

	L	T	T1	H	H1	K	K1	CH	DEPTH	ISO 5211	PCD	N-M	WEIGHT
APD50	257	75	40	90	70	9	80	11X11 14X14	13 14	F03/F05/F07	35/50/70	4-M5/M6 /M8	1.6
APD65	314	89	46	107	87	13	80	14X14	17	F05/F07	50/70	4-M6/M8	3
APD80	430	101	50	126	106	13	80	17X17	19	F07	70	4-M8	5.3
APD100	500	129	62	148	128	19	80	22X22	26	F07/F10	70/102	4-M8/M10	9.5
APD125	606	151	72	174	154	19	80	22X22	26	F07/F10	70/102	4-M8/M10	17.6
APD140	682	164	77	192	172	24	80	22X27 27X27	30	F10/F12	102/125	4-M10/M12	23.9
APD160	781	188	89	216	196	24	80	27X27 36X36	30	F10/F12 F14	102/125 140	4-M10/M12 4-M16	36.6
APD185	894	217	102	254	224	30	130	22X22	30	F07/F10	70/102	4-M16	57
APD210	982	231	115	284	254	36	130	36X36 46X46	50 60	F14 F16	165	4-M20	77.2
APD250	1108	301	152	335	305	36	130	55X55	60	F07/F10	70/102	4-M20	119.6

